

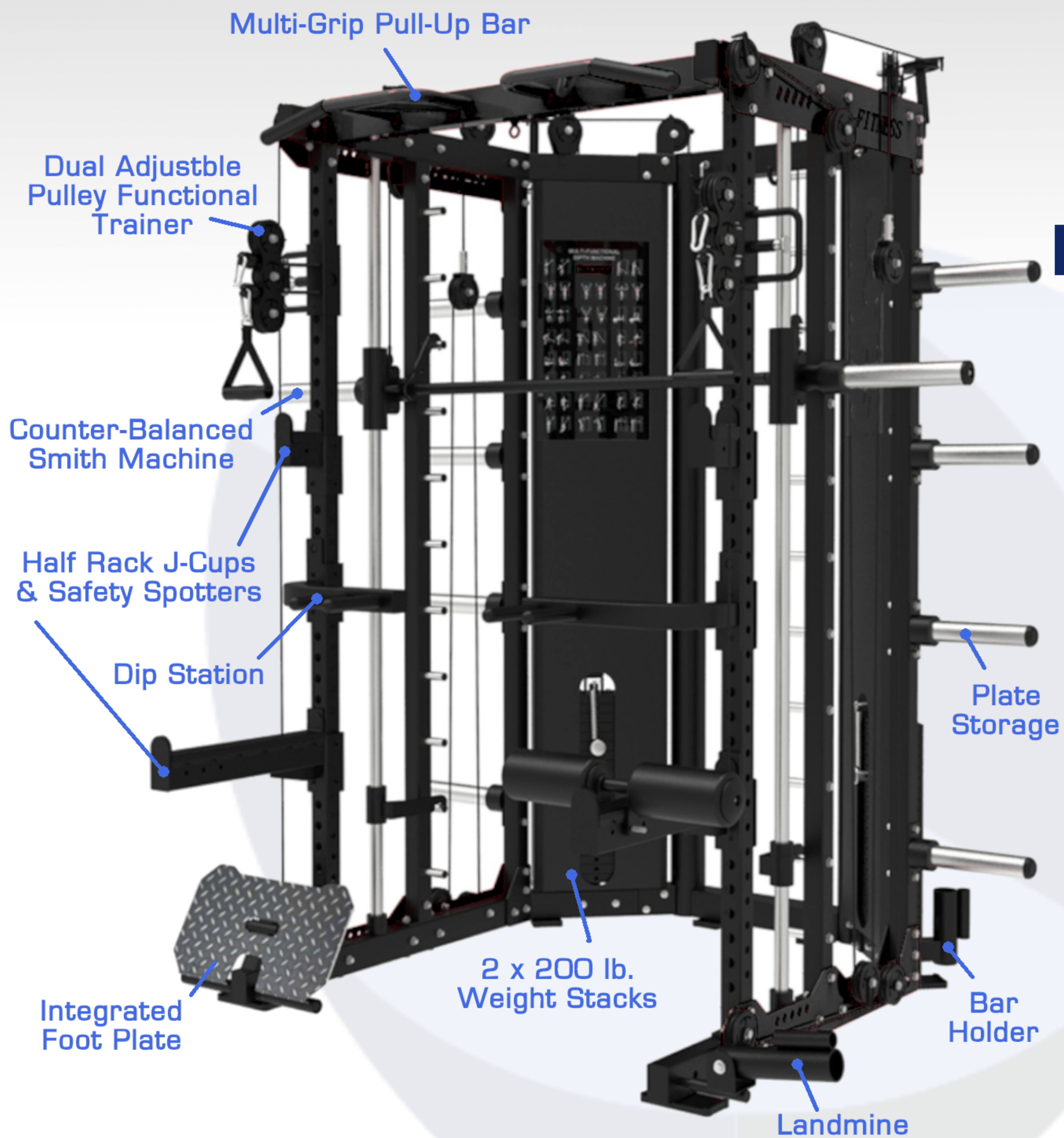

PARADIGM™

Life is not a spectator sport



Optional Seat Station



Optional Vertical Leg Press

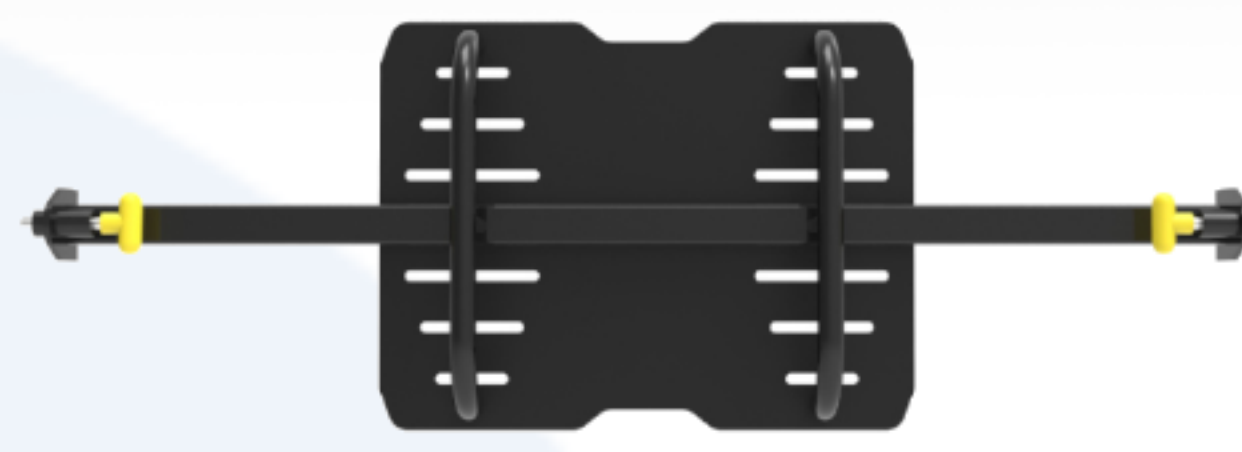

Optional Lever Arm Kit



Included Accessories

- 7ft. Lifting Bar
- Spring Collars
- Exercise Handles
- Dip Handles
- Lat Bar
- Activity Bar
- Short Bar
- Triceps Rope

CAGES / RACKS DSHR-2S PRO

A Fully-Loaded & Family Friendly "All-In-One" Trainer.

Features

- ✓ Dual Adjustable Pulley Functional Trainer (2:1 & 4:1 Cable Ratios)
- ✓ Counter-Balanced Smith Machine with Linear Bearings
- ✓ Half Rack with Adjustable Spotters & J-Cups
- ✓ Integrated Pull-Up, Dip & Landmine Stations
- ✓ Integrated Bar, Plate & Accessory Storage

HEVY
Workout logging
made simple

Download on the App Store | GET IT ON Google play

Specifications:

Dimensions: (L x W x H): 66" x 77" x 86" / 168 x 195 x 219cm
 Weight Rating: Unit = 992 lb. / 450 kg, Smith Machine = 772 lb. / 350 kg
 Functional Trainer Weight Stack: 2 x 200 lb.
 Cable Rating: 6.2mm nylon coated tested to 2000 lb.
 Functional Trainer Pulley Ratios: 2:1 & 4:1
 Pads: High Resilience Polyurethane Foam
 Product Weight: 884 lb. / 401 kg

Lifetime Residential Warranty*

Light Commercial Warranty*

*Visit paradigmfitnessequipment.com/warranty-information for full details



Paradigm Fitness Equipment
 P.O. Box 24681, Silverthorne, CO, 80497
 (800) 910 6194
paradigmfitnessequipment.com

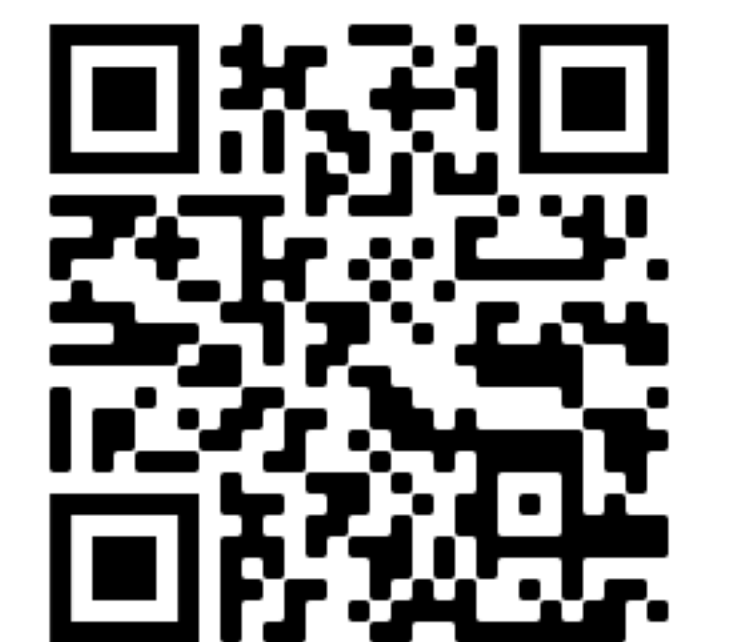

Scan me